

# SMART SWITCH TECHNOLOGIES

---



## FR-4000 Fire Alarm Monitor Installation Manual

# Table of Contents

Introduction	1
System Components	2
Wiring Block Diagram	3
Connection Diagram For One Sensor	4
Connection Diagram For Multiple Sensors	5
Wiring Block Diagram – Single Engine Room Layout	6
Wiring Block Diagram – Twin Engine Room Layout	7
Wiring Diagram for FR-4000	8
Wiring Diagram for FR-100	9
Connection Diagram for FEC -6 & FEC-1	10
Installation & Electrical Specifications	11
Mounting Instructions	12
System Overview	13
Relay Operations	14
Programming Instructions	15
Programming Instructions Cont.	16
Programming Instructions Cont.	17
Programming Instructions Cont.	18
Operating Instructions	19
Installation Instructions	20

# Introduction

Thank you for purchasing the FR-4000 Fire Alarm Monitor. Smart Switch Technologies is very proud to be able to provide this product to you. You have selected a capable system designed to provide years of reliable service under the most demanding conditions.

Smart Switch is a pioneer in the design and development of distributable intelligence controller systems for the marine industry. The FR-4000 Fire Alarm Monitor is a versatile, compact, modern, stylish, user-friendly intelligent network system. Our Research and Development Team have developed this system specifically for the marine environment using proven techniques and materials, which will ensure a long life at sea.

The FR-4000 provides features found only in expensive computer-based systems on mega-yachts, but does so for a fraction of the cost. It is an economical and capable alternative to simplistic monitoring systems. The FR-4000 allows builders and retrofitters to offer a system with maximum functionality thereby providing boat owners with excellent visibility into any alarm condition.

The main features are:

- 12/24 volt auto detect
- Early detection and warning of engine room fire
- Full machinery shutdown management for up to six devices
- Fire detection throughout vessel
- Full monitoring of extinguisher trigger cupboard door
- Comprehensive fault monitoring
- Cylinder pressure monitoring
- Up to 4 zones

# System Components

## FR-4000 Master Display Unit (MDU)

Provides the following functions:

- 12/24 volt
  - Early detection and warning of engine room fire
  - Full machinery shutdown management for up to six devices (see FEC-6)
  - Comprehensive fault monitoring
  - Cylinder pressure monitoring (see FEC-6)
  
  - Latched display for up to 4 Alarms
    - All names are user programmable
    - Network communication fault
    - Visual alarm with tone
- 

## FR-100 Input/Output Unit (IOU)

The FR-100 is a controller, which provides 4 Zone Inputs for Smoke Sensors and 1 Output Relay.

- Each Input requires 4K7 end of line resistor for supervised line
  - **Minimum fault sense current = 8mA**
  
  - Output Relay's
    - 10 A resistive @ 24VDC
    - Relay 1 & Relay 2 close on Fire detection
    - Relay 1 opens when alarm is muted
    - Relay 2 opens when all zones are OK
- 

## FEC-1 Engine Relay Controller

The FEC-1 has one relay.

- Output Relay 1 = 3 amp inductive
- 

## FEC-6 Engine Relay Controller

The FEC-6 has six relays.

- Output Relay 1 to 4 = 10 A resistive @ 24VDC
  - Output Relay 5 & 6 = 1 A resistive @ 30VDC
- 

## Pyro-5 Pyrogen interface module

Monitor and release up to 5 Pyrogen extinguisher bottles.

# Wiring Block Diagram

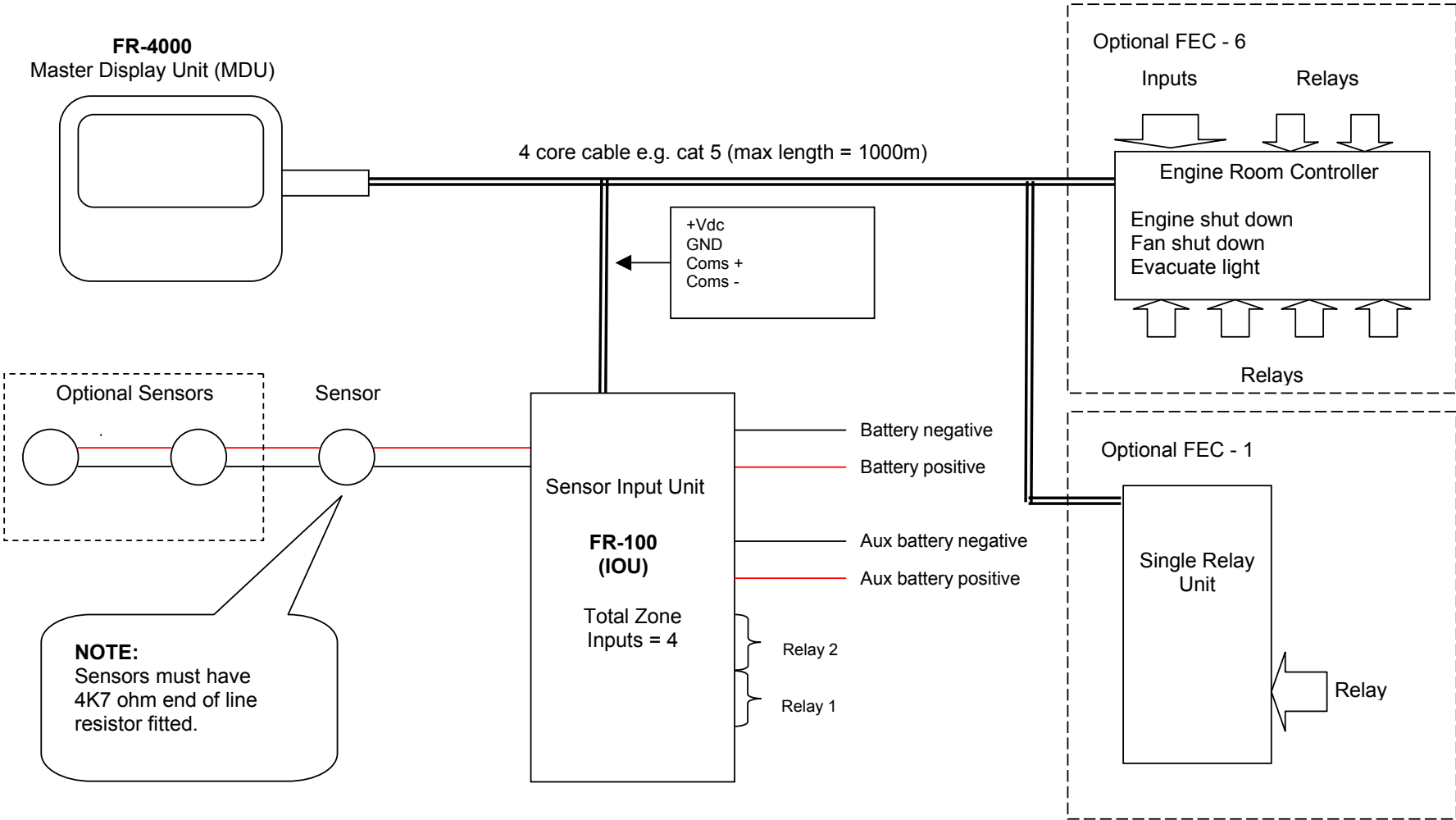

## Connecting One Sensor Per Zone

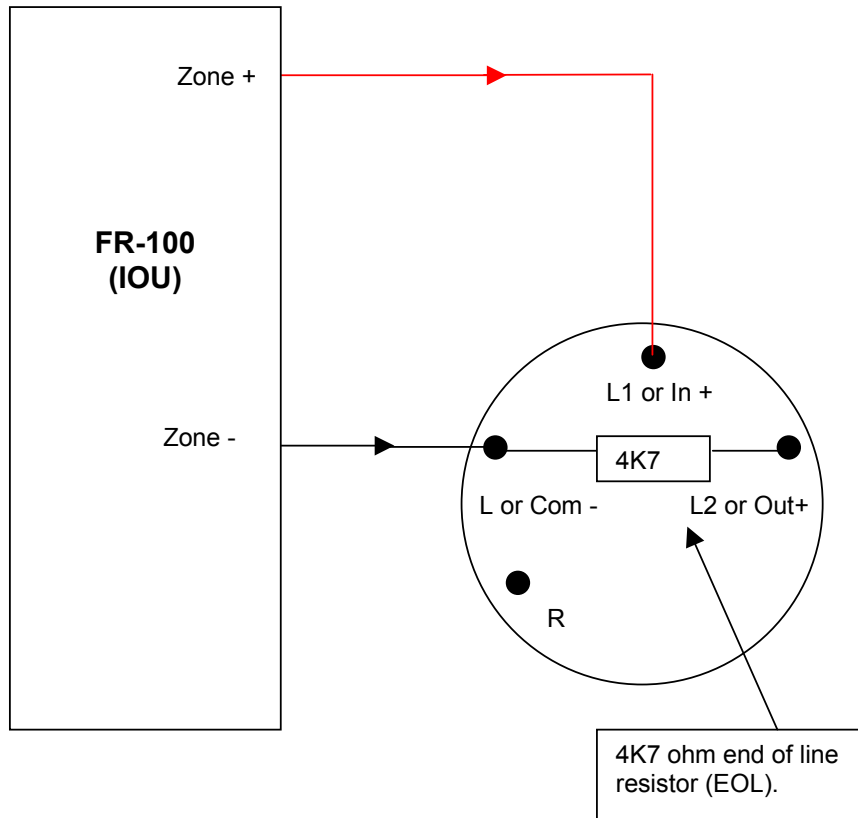

**Note:** Detector manufactures use different terminal designators, E.g. L1, L2, L3 **OR** Com -, In +, Out +

## Wiring for the extinguisher trigger cupboard door

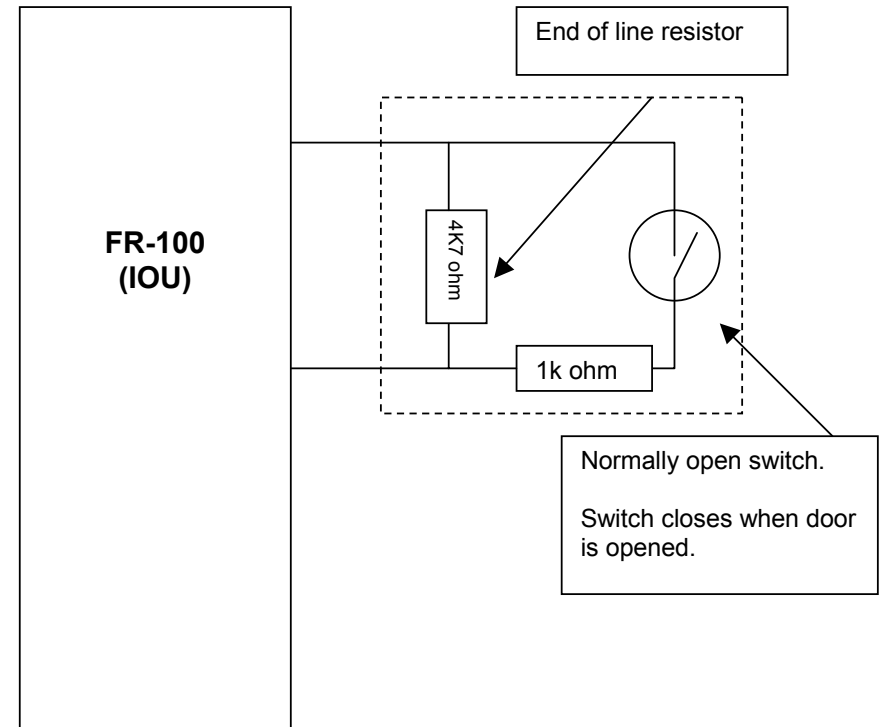

# Connecting Multiple Sensors Per Zone

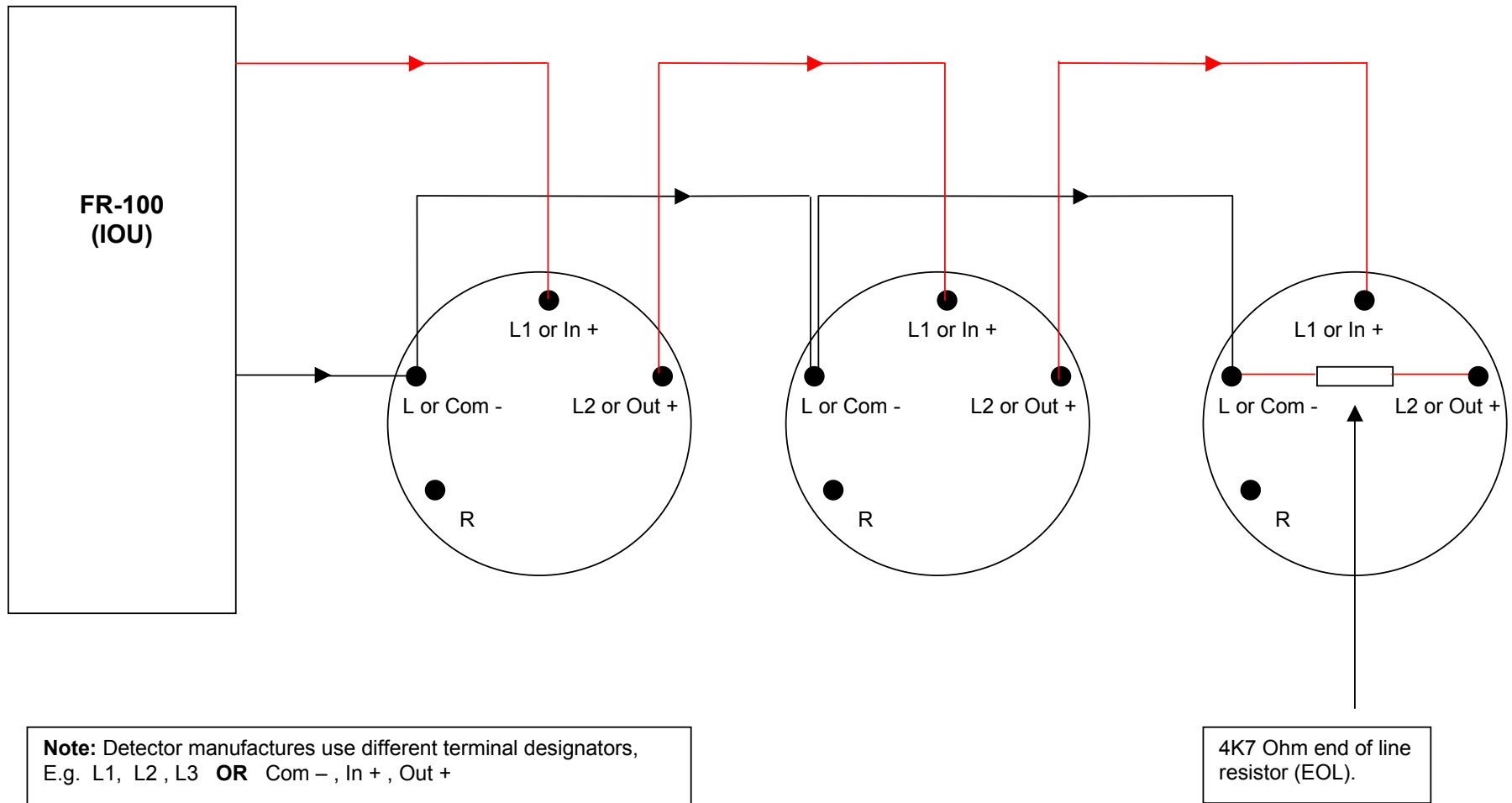

# Single Engine Room Layout

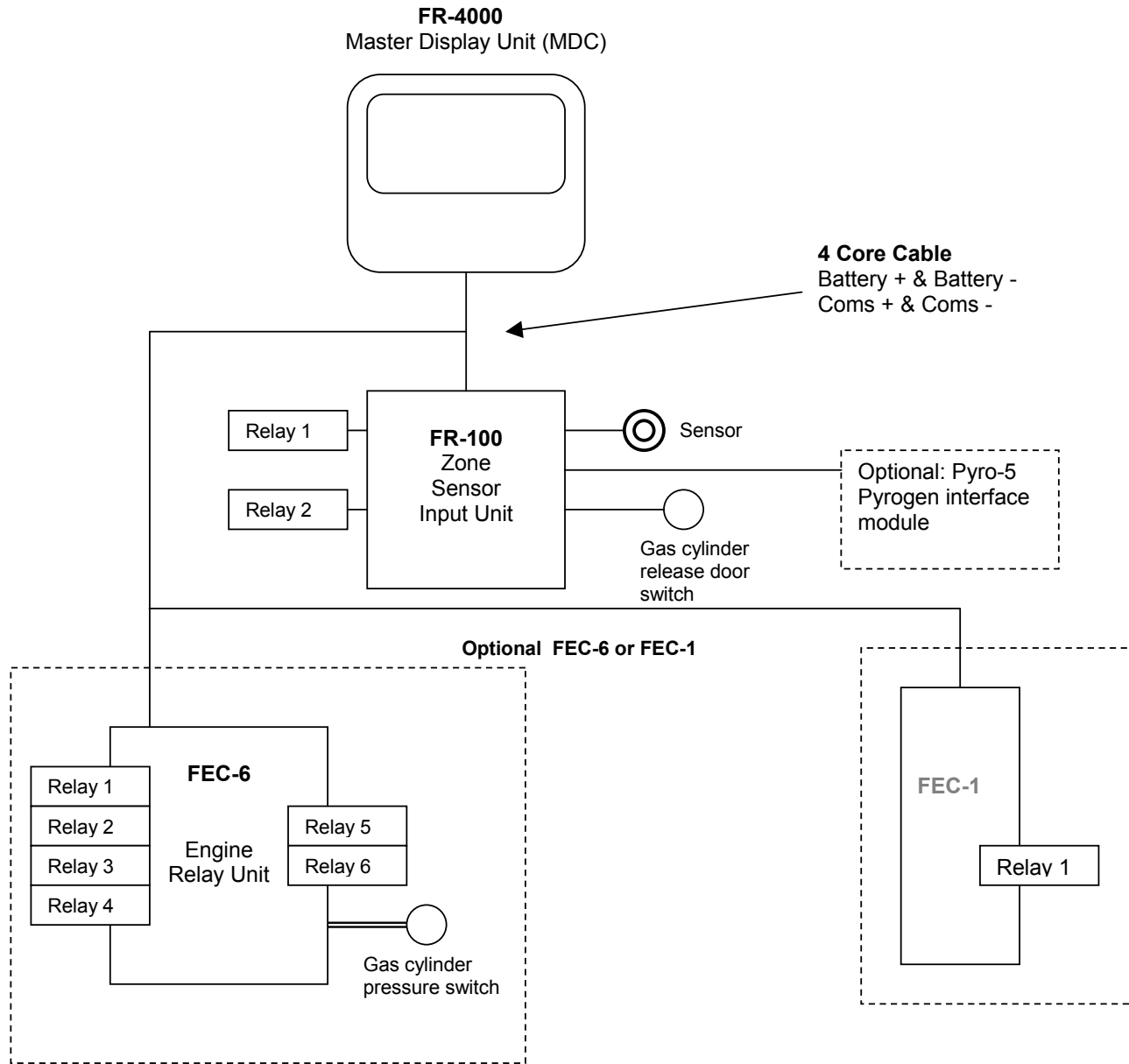



# Twin Engine Room Layout

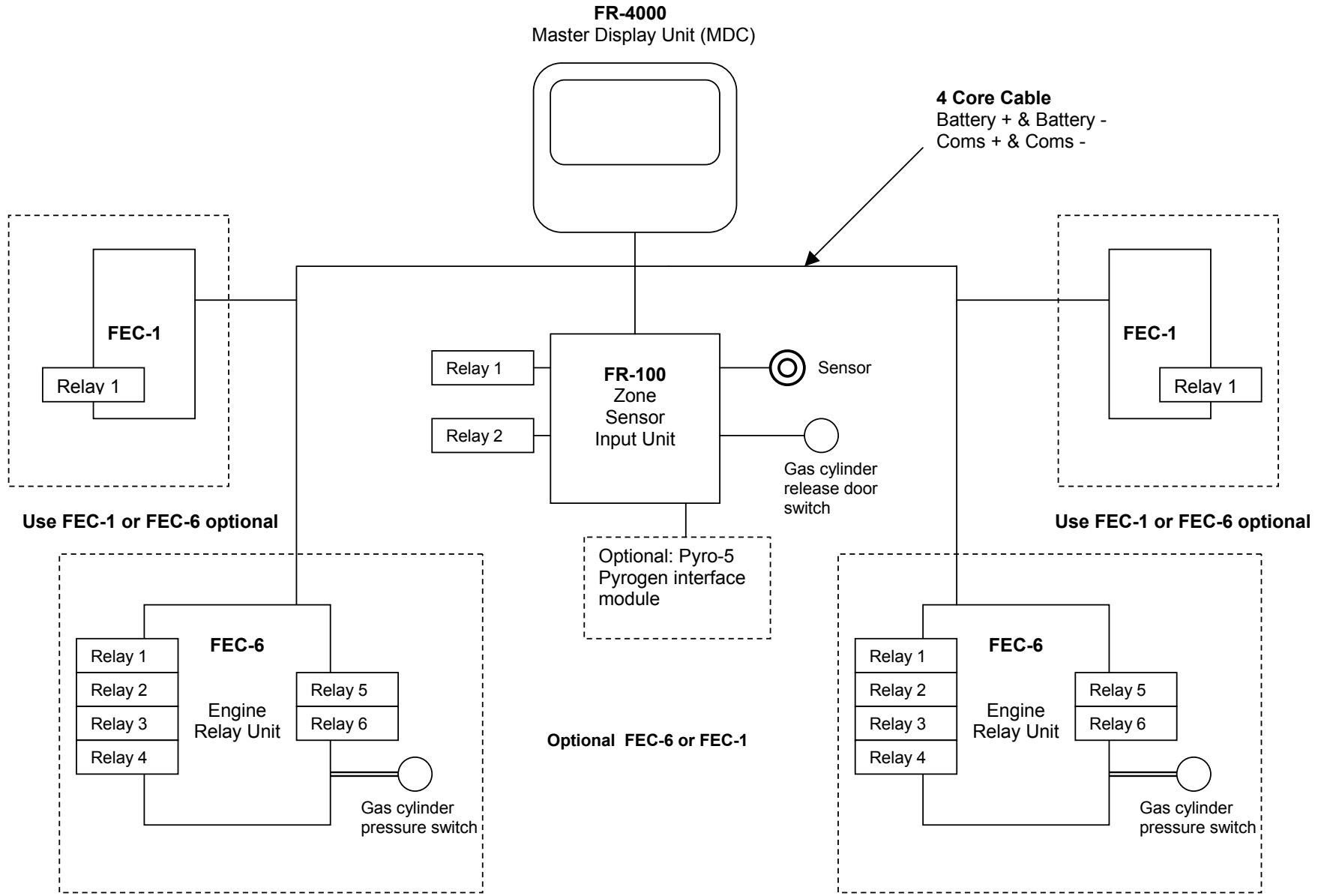

## FR-4000 Display Wiring Connections:

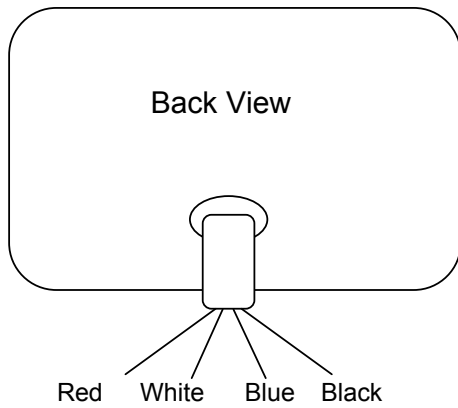

### Connections

Red = +Vdc

Black = GND

Blue = Coms +

White = Coms -

## Power and Comms Wiring Connections:

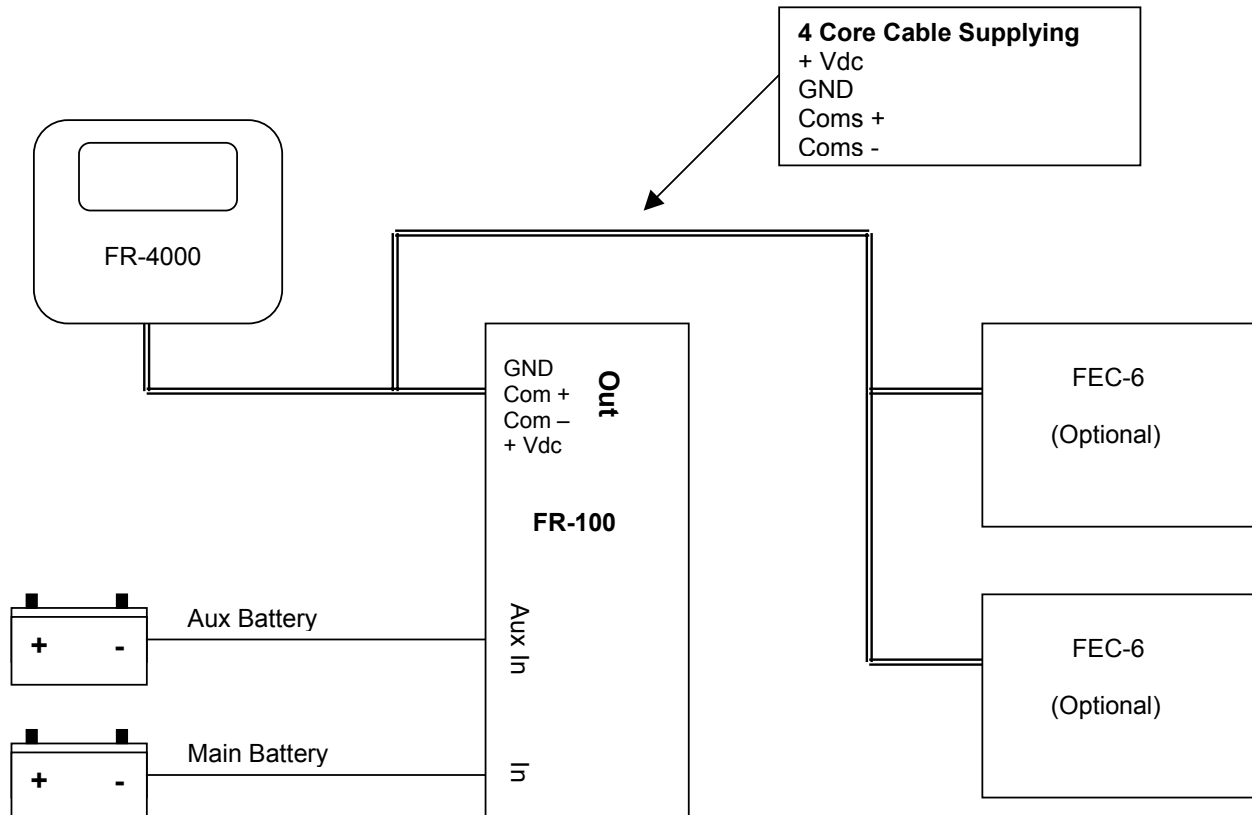

# Wiring Diagram for Input/Output Unit FR-100

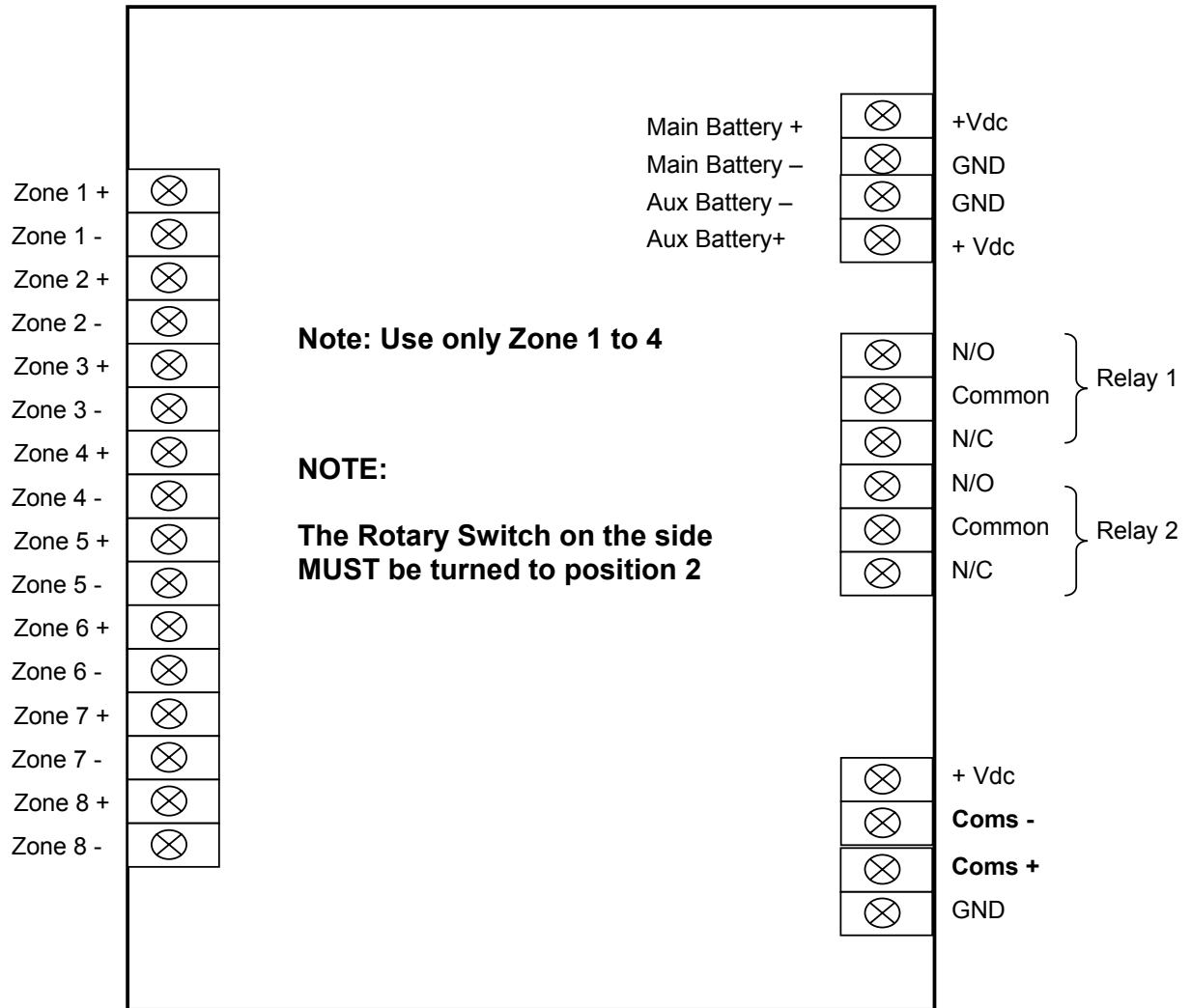

**Note: If you require the Aux Battery to be charged by the Main Battery supply then fit D1 charging diode (IN 5404) as per below. The stripped band on the diode should be connected to the Aux Battery + terminal.**

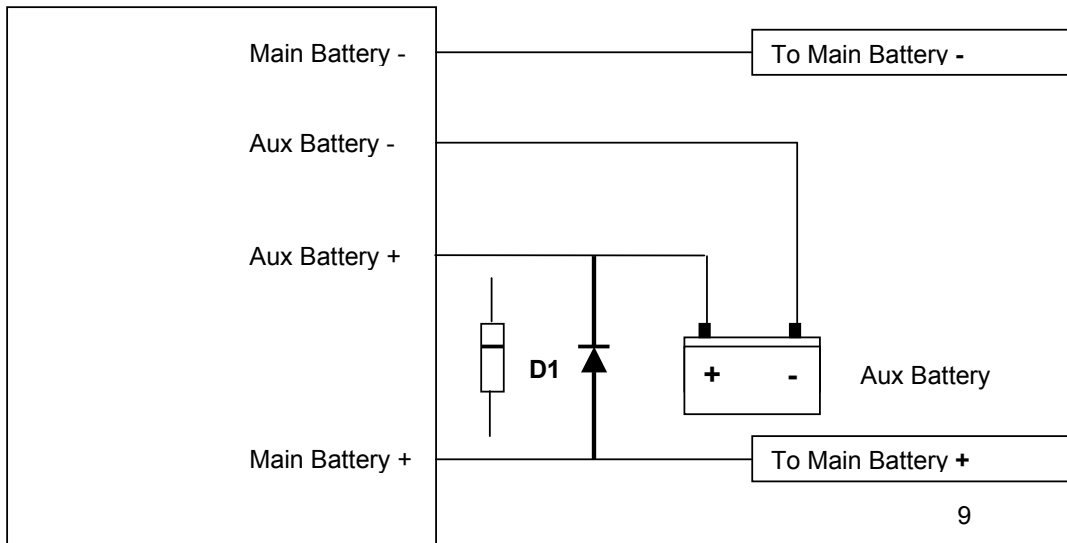

# Connections for FEC-6

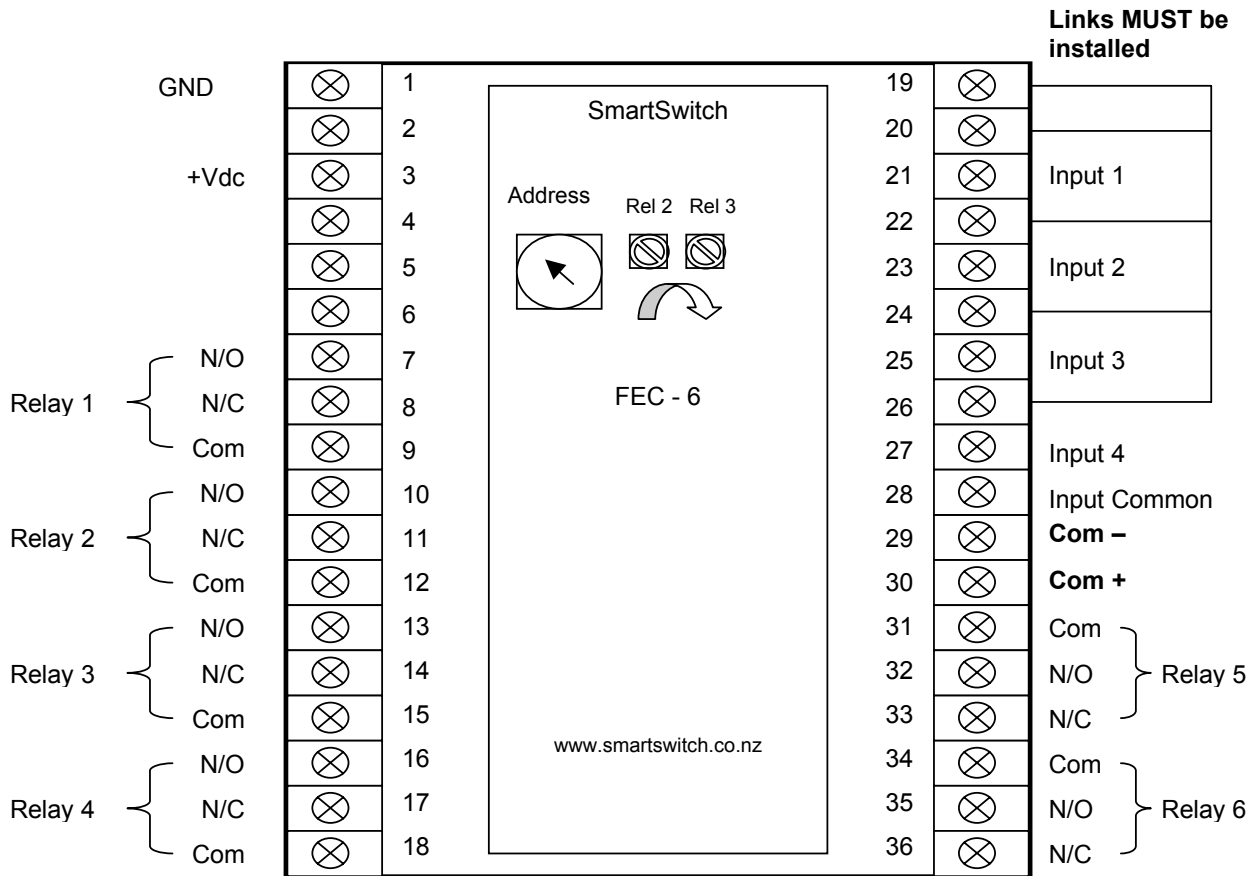

## Connections for FEC-1

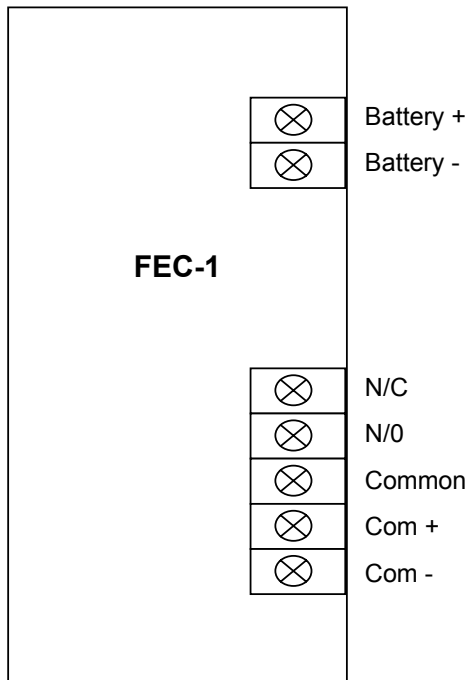

## Inputs for FEC-6

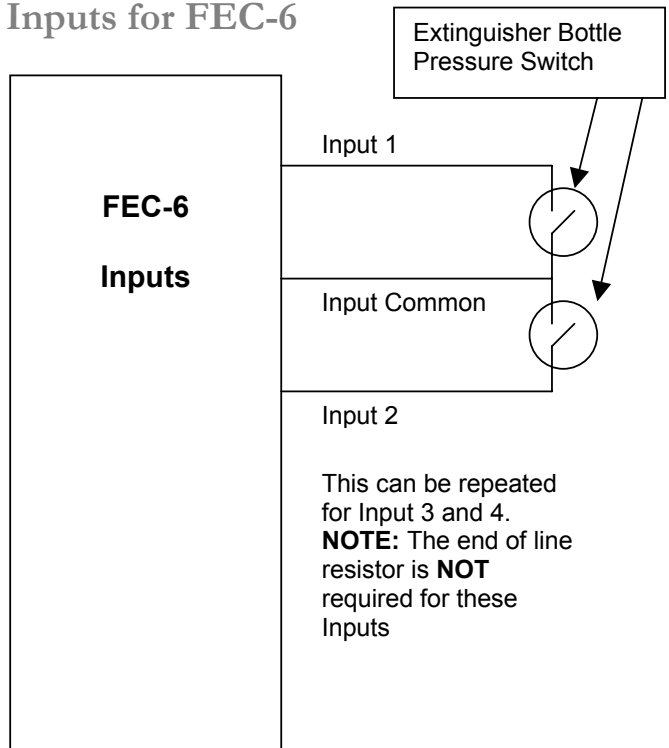

# Installation Steps

**Smart Switch recommends that a Qualified Marine or Auto-Electrician install this product.**

## Step 1:

Install and connect the Master Display Head Unit (FR-4000).

## Step 2:

Install and connect the IOU (FR-100) and connect Sensors.

## Step 3:

Install and connect FEC-1/FEC-6 if applicable.

## Step 4:

Program the Display Unit (FR-4000).

---

## Electrical Specifications FR-4000

Supply Voltage	10 to 30 Volts DC (Auto-Sensing)
Quiescent Current	50mA (backlight off)
Data Retention	50 years (without power)

## Electrical Specifications FR-100

Supply Voltage	10 to 30 Volts DC (Auto-Sensing)
Quiescent Current	30 mA
Min fault sense current	8mA
Relay 1	10 A resistive @ 24VDC
Relay 2	10 A resistive @ 24VDC

## Electrical Specifications FEC-1

Supply Voltage	10 to 30 Volts DC (Auto-Sensing)
Quiescent Current	10mA
Relay 1	3 amps Inductive

## Electrical Specifications FEC-6

Supply Voltage	10 to 30 Volts DC (Auto-Sensing)
Quiescent Current	200 mA
Relay 1 to 4	10 A resistive @ 24VDC
Relay 5 & 6	1 A resistive @ 30VDC

## Network Cable

The cable connecting the Display Unit to the Input/Output Units is referred to as the network cable and may run up to 1000 meters in total length.

# Mounting Instructions

Position the mounting template tool provided and mark all three pilot holes. Drill a 3mm hole on the two outside holes and fit the mounting screws provided. Place the template tool back over the screws and tighten the screws until the template tool can just slip on and off the screws (ensure the tool is not too loose).

Drill the bottom hole to 12 mm (cable hole).

Place the Display Unit keyholes over the two screws and gently pull down. If the screws have been tightened to the correct depth the Display will clip down and self tighten.

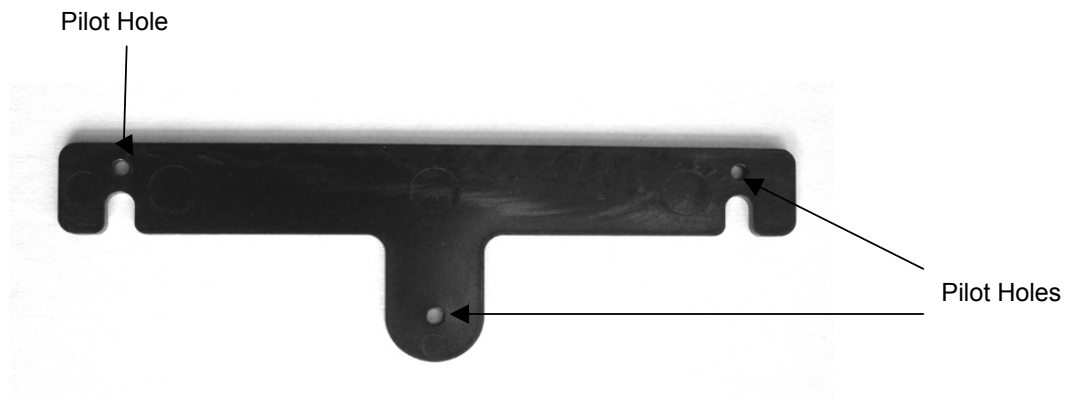

# System Overview

The FR-4000 Alarm Monitor has been developed to allow monitoring of up to 4 zones. It is a network-based system consisting of a Master Display Unit (FR-4000), a Sensor Input Unit (FR-100), Smoke Sensors and an optional Engine Room Relay Controller (FEC-6).

A 4-wire network cable interconnects all devices. The Master Display Unit (MDU) controls communication with the Input / Output Unit (IOU). System components may be located anywhere on the network cable and the cable may be up to 1000 meters in length.

Each area which are referred to as zones, can have multiple sensors. An Engine Room Relay Controller can be fitted (model FEC-6) and any zone can be associated to that engine relay box.

If there is a fire in a zone associated to the engine relay box - in auto mode it will automatically shut down fans, fuel pumps and/or any device attached to that relay box (see page 14 for relay details). In manual mode it will ask you to press the enter key to start this process.

An extinguisher trigger cupboard door or doors may be connected to a Sensor Input Unit (FR-100).

This input is fully monitored and if the extinguisher trigger cupboard door is opened then the alarm buzzer will sound, the Master Display Unit will display 'Open' and relays 5 & 6 will close on the Engine Room Relay Controller (FEC-6) or relay 1 on (FEC-001). See page 14 for relay details.

The extinguisher bottle pressure switch may be connected to the Engine Room Relay Controller (FEC-6) see page 10 for details.

This input is monitored and if the extinguisher bottle is empty the Master Display will display "Empty" if full it will display "OK"

Input 1, 2, 3 and 4 are all internally connected in the FEC-6 so multiple bottles may be connected. If multiple bottles are connected and one is empty the display will show "Empty" therefore all bottles will need to be inspected to locate the empty one.

## **Optional:** Pyro-5 Pyrogen interface module

This module will monitor up to 5 Pyrogen extinguisher bottle's, also has bottle release input.

# Relay Operations

## Model FEC – 6:

An Engine Room Relay Controller can be fitted (model FEC-6) and any zone can be associated to that engine relay box.

If there is a fire in a zone associated to the engine relay box - in auto mode it will automatically shut down fans, fuel pumps and/or any device attached to that relay box, in manual mode it will ask you to press the Ent key to start this process.

When a fire is detected in a zone that has been associated with the engine controller (FEC-6) and the FR-4000 (MDU) is in **Manual Mode** the display will show:

ENGINE ROOM FIRE

PRESS ENT KEY TO  
STOP ENGINE & FANS

PUSH ISOL TO ISOL

When the Ent key is pressed the following will happen on the FEC-6:

Relay 1, 2, 3 and 4 will activate.

Relay 2 and 3 can be delayed by adjusting the trim pot (next to the address select rotary switch) marked Rel 2 and Rel 3. Rel 2 adjusts the time for Relay 2 and Rel 3 adjusts the time for Relay 3. Turn Anti-clockwise to increase time.

Relay 2 Min time = 0 seconds, max time = 1 minute.

Relay 3 Min time = 0 seconds, max time = 1.5 minute

Relay 4 has a delay associated to it called the Eng Stop Time, which is setup in the Controller Menu on the FR-4000 (MDU). When the programmed time has elapsed Relay 4 will activate.

Example: If the solenoid on the extinguisher bottles is connected Relay 4 and the stop time is set to 30 seconds, this would give a 30 second window for the fans and engine (connected to Relay 1 & 2) to stop before the extinguisher is set off.

Relay 5 & 6 are associated with the manual extinguisher trigger cupboard door.

If the extinguisher trigger cupboard door is opened Relay 5 & 6 will activate. Relay 6 will stay activated until the door is closed, Relay 5 will deactivate when the Mute key is pressed on the FR-4000 (MDU). Example: Relay 6 connected to the evacuate engine room light and Relay 5 connected to a buzzer.

When a fire is detected in a zone that has been associated with the engine controller (FEC-6) and the FR-4000 (MDU) is in **Auto Mode** the above will happen automatically.

## Model FEC – 1:

The FEC-1 is a single Relay unit, which could be used instead of the FEC-6 if only 1 Relay is required. Example: To turn on the evacuate engine room light.

## Model FR-100:

The FR-100 has two relays Relay 1 & Relay 2. Both Relay 1 and Relay 2 will only activate on Fire detection. Relay 1 will de-activate when the alarm is muted while Relay 2 will stay activated while Fire is displayed on the MDU.



# Programming Instructions

## Step 1: Placing the unit in Program Mode

Press and hold down the Mute & Select Up keys together for 3 seconds. This will bring you to the Set-Up Menu and place the unit in program mode.

The display will show:

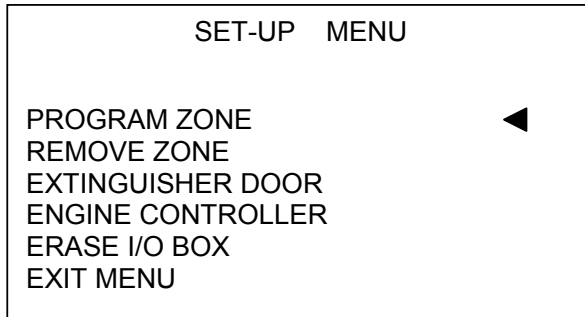

Scroll to PROGRAM ZONE and press the Ent key.

## Step 2: Program Zone

The display will now show:

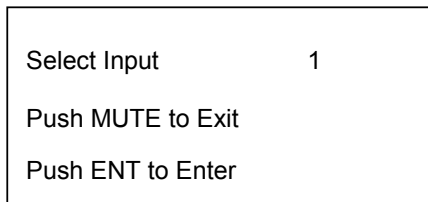

Use the Select Up or Down key to change the Input number, which corresponds to the Input being programmed.

Once the Input number has been selected press the Ent key to accept.

## Step 3: Selecting /Creating Zone Name's

The display will now show:

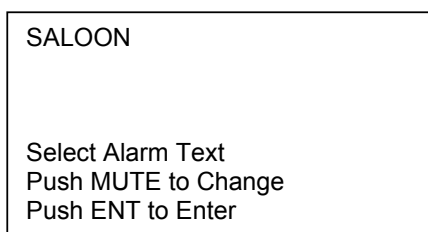

Use the Select Up or Down key to scroll through the pre-named zone names. Once you have found the one required press the Ent key.

If you would like to create your own name press the Mute key. Use the Select up or down key to scroll through the alphabet and the Dim up or down key to change to the next character. When finished press the Ent key.

#### Step 4: Next or End

The display will now show:

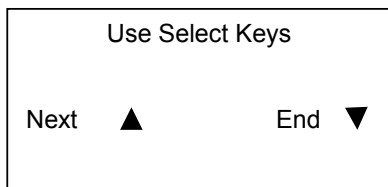

Press the Select Up key to set-up the next Input or Select Down key to end and return to the Set-Up Menu.

#### REMOVE ZONE:

Zones can be removed by scrolling to REMOVE ZONE, in the Set-Up Menu and pressing the Ent key.

The display will now show:

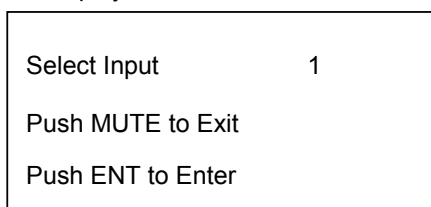

Use the Select Up or Down key to change the Input number, until you find the one which corresponds to the Zone you wish to remove. Once the Input number has been selected press the Ent key to accept.

#### EXTINGUISHER DOOR:

If the vessel is fitted with an extinguisher cupboard holding the extinguisher trigger cable, the door will need to be monitored. From the Set-Up Menu scroll to EXTINGUISHER DOOR and press the Ent key.

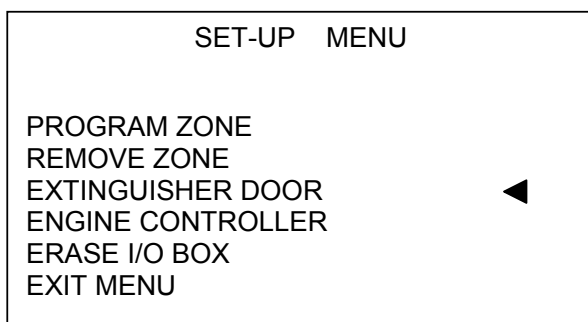

The display will now show:

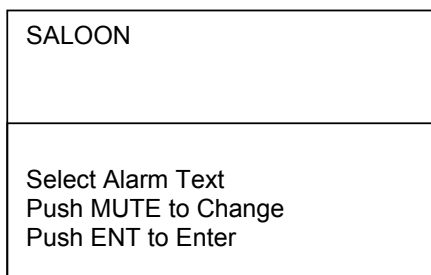

Use the Select Up or Down key to scroll through the pre-named zone names. Once you have found the one required press the Ent key.

If you would like to create your own name press the Mute key. Use the Select up or down key to scroll through the alphabet and the Dim up or down keys to change to the next character. When finished press the Ent key.

**You now need to associate the door switch with a relay controller (FEC-6 or FEC-1).**

If a FEC-6 is installed Relay 5 & 6 will activate when the extinguisher door is opened. Relay 6 will stay activated until the door is closed, Relay 5 will deactivate when the Mute key is pressed on the FR-4000 (MDU). If a FEC-1 is fitted the Relay will activate when the door is open. The zone needs to be associated with either the Port or Stb (FEC-6) engine controller. If there is only a FEC-1 fitted then you can choose either Port or Stb, as either will work.

The display will now show:

SET THE ENGINE BOX ASSOCIATED WITH ZONE
Select Eng I/O Port Push MUTE to Exit Push ENT to Enter

Use the Select Up or Down key to scroll between Port and Stb, (if the vessel is single engine room then just select Port) and press the Ent key to accept.

**ENGINE CONTROLLER:**

If a FEC-6 or FEC-1 is installed, scroll down to ENGINE CONTROLLER and press the Ent key.

SET-UP MENU
PROGRAM ZONE
REMOVE ZONE
EXTINGUISHER DOOR
ENGINE CONTROLLER ◀
ERASE I/O BOX
EXIT MENU

You will now see a new Menu. This is the Engine Room Controller Set-Up Menu and is used to associate a zone with the FEC-6 engine room controller

The system will now display:

ENGINE CONTROL MENU
SET ZONE ◀
REMOVE ZONE
ENG STOP TIME
AUTO / MANUAL
EXTINGUISHER INPUT
EXIT MENU

## SET ZONE:

**Once a zone has been programmed (refer to programming on page 15) you can perform the following:**

This allows you to join any programmed zone to either the Port or Stb (FEC-6) Engine Relay Controller (if the vessel is single engine room then just select Port). Scroll with the Select Up or Down key through the programmed zones, until you find the zone required, and then press the Ent key to accept.

## REMOVE ZONE:

This removes the association of a zone that is associated with either the Port or Stb (FEC-6) Engine Relay Controller. NOTE: This only removes the association and NOT the zone.

## ENGINE STOP TIME:

This sets the time delay for Relay 4 on the FEC-6. If the solenoid on the extinguisher bottles is connected Relay 4 and the stop time is set for example to 30 seconds, this would give a 30 second window for the fans and engine (connected to Relay 1 & 2) to stop before the extinguisher is set off. Also see page 14 for details.

## AUTO /MANUAL: (Default = Manual)

If Auto mode is selected and there is a fire in the zone that the FEC-6 is attached (e.g. Engine room) you will NOT be asked if you want to shut down the fans and engine the system will automatically do it. If manual is selected the system will ask you. See Relays page 14.

## EXTINGUISHER SWITCH INPUT:

The extinguisher bottle pressure switch may be connected to the Engine Room Relay Controller (FEC-6) see page 10 for details. This input is monitored and if the extinguisher bottle is empty the Master Display will display "Empty" if full it will display "OK".

Input 1, 2, 3 and 4 are all internally connected in the FEC-6 so multiple bottles may be connected. If multiple bottles are connected and one is empty the display will show "Empty" therefore all bottles will need to be inspected to locate the empty one.

Scroll down to ENGINE CONTROLLER at the Set-Up Menu and press the Ent key.  
Now scroll down to EXTINGUISHER INPUT and press the Ent key.  
This set-up is the same as in Step 2 page 15.

Use the Select keys to scroll to the zone you want to use, select the name as in Step 3 page 15 then press the Ent key.

The display will now show:

SET THE ENGINE BOX ASSOCIATED WITH ZONE
Select Eng I/O Port Push MUTE to Exit Push ENT to Enter

Use the Select Up or Down key to scroll between Port and Stb, (if the vessel is single engine room then just select Port) and press the Ent key to accept.

**Note: The end of line resistor is NOT required for this input.**

### EXIT MENU:

This will take you back to the Set-Up Menu (Step 1, page 15).

### ERASE I/O BOX:

To erase all settings associated with the FR-100 (IOU), scroll to ERASE I/O BOX and press the Ent key.

**Note: If a mistake is made on any input a complete erase is not required just reprogram the input.**

The display will now show:

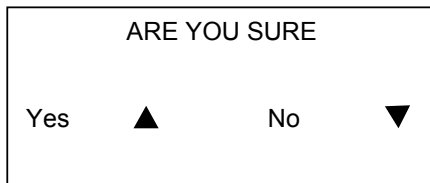

If Yes is selected the complete I/O Box settings will be erased and the system will return back to the Set-Up Menu.

If No is selected the system will return to the Set-Up Menu.

### EXIT MENU:

Once all zones have been programmed you will need to take the system out of Set-Up mode. From the Set-Up Menu scroll down to EXIT MENU and press the Ent key.

This will save all associated data that has been set and take the system out of program mode and put it into monitoring mode. The FR-4000 is now ready for use!

## Operating Instructions

### Alarms:

Should a Smoke Sensor detect smoke, or fire, the text **FIRE** will flash on the display. The audible alarm will sound and both Relay 1 and Relay 2 in the FR-100 will close.

Pressing the Mute key will mute the alarm and the Relay 1 in the FR-100 will open. If the fault condition is still present the alarm text will stop flashing and stay solid on the display. Relay 2 in the FR-100 will stay closed until the fire alarm has been cleared.

### Isolate:

Use the Select keys to scroll to the zone requiring Isolation and press the ISOL key.

To undo simply repeat the above.

### Reset:

Pressing the Reset key will reset all sensors that are on.

### Test Mode:

Press and hold the Mute key for 3 seconds (you will hear a bleep every second). The system will now display a Test Menu. Use the Select keys to select the option you want to test and press the ENT key. The system will test all programmed zones or relays.

# Installations Instructions

## **WARNING !!**

This equipment is NOT intended for use in the following locations and requiring protection

- the salt spray (mist) test in ABS Rules Table 4/11.1 (1996),
- the salt spray (mist) test in Lloyd's Register Type Approval System, Test Specification No. 1 (1990), or
- ASTM B 117-95 for 200 hours and does not show pitting, cracking, or other deterioration more severe than that resulting from a similar test on passivated AISI Type 304 stainless steel.

Locations requiring an exceptional degree of protection means - a location exposed to weather, seas, splashing, pressure-directed liquids, or similar moisture conditions. These locations include--

- (1) On deck;
- (2) A machinery space;
- (3) A cargo space;
- (4) A location within a galley or pantry area, laundry, or water closet which contains a shower or bath; and
- (5) Other spaces with similar environmental conditions.

© All technologies, design and Intellectual Property is owned by  
Smart Switch Technologies Ltd  
Po Box 272, Waikanae, New Zealand  
Ph: 0064-4 293-4201 Fax: 0064-4 293-4201  
Mobile: 0064-274-919-805  
Email: [info@smartswitch.co.nz](mailto:info@smartswitch.co.nz) Web: [www.smartswitch.co.nz](http://www.smartswitch.co.nz)