

Monitor/Control up to 8 bilges from one location

The **BC-4000 and BC-8000 Bilge Monitoring/Control System** provide intelligent networked solutions for the monitoring and control of up to four or eight bilge areas. The diagram (below) shows a typical system layout. The system consists of the BC-4000/8000 display controller, up to 4 or 8 BC-100 or BC-100/P controllers, and one (optional) RB-800 repeater displays. The system communicates via a 2-wire network cable with a maximum cable length of 1000 meters.

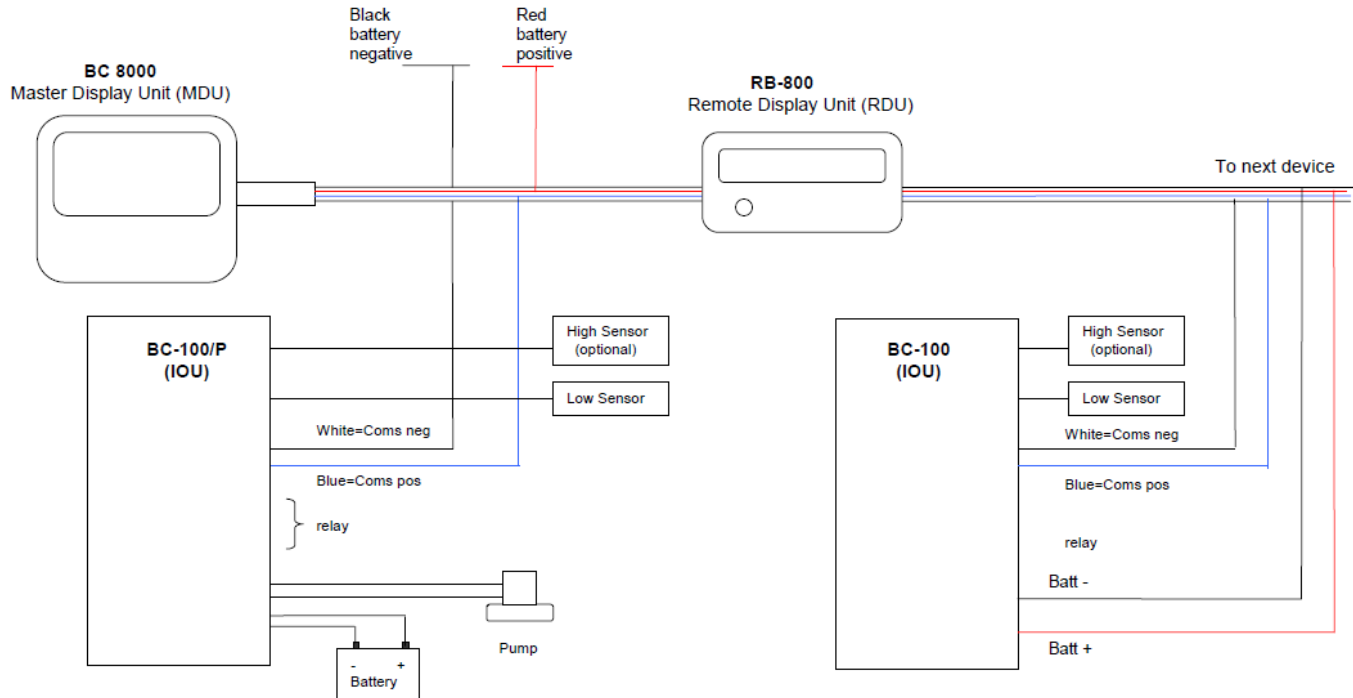

BC-4000/8000 DISPLAY CONTROLLER: Is a powerful bilge control system.

- Full control from one central location on your boat.
- Delay pump on and off time (programmable).
- Pump on alarm time (programmable).
- Visual status display for each bilge area showing pump status, low sensor status, last pump run time, number of pump-runs, program & operate modes.
- Turn bilge pumps on/off manually or automatically
- Visual & audible alarm for any fault conditions e.g. high water, low sensor fault, pump fault, time alarm.
- Two master modes of operation automatic or semi-automatic.
- Individual modes auto or manual.
- All bilge areas are name programmable giving location e.g. (Aft Port) (Engine Room) (Mid Ship Starboard).



BC-100 or BC-100/P I/O UNIT: Are controllers which manage the pump, relay, and high/low sensors.

- Automatically switch to standalone mode if communication with the BC-8000 is lost providing normal operation of bilge pumps if either the hi or low sensors turn on.
- Controls the pump and provides the input for the hi & low sensors.
- Pump output = 88 amps @ 12 vdc.
- Operates with any standard float switch or SmartSwitch FS-2A.
- Alarm relay = 3 amp inductive.
- Supplied in two different models:
 - **BC-100/P** with inputs for hi & low sensors - output for alarm relay and pump
 - **BC-100** with inputs for hi & low sensors and output for alarm relay

RD 800 The Remote Display Unit may be connected anywhere on the vessel for convenient monitoring.



Electrical Specs:

- Supply Voltage: 12 ~ 32 Volts DC (Auto sensing)
- Quiescent Current: 26 Milliamps (with backlight off)
- Reverse polarity protected
- Network cable length=1000m
- Voltage & EMI Protected
- Programmed Data Retention: 50 years (without power)

The BSW-1000 Single Bilge Controller provides visibility at the helm and pump control for a single bilge application. Features are shown in the chart below.



Comparison of SmartSwitch Bilge Control Solutions



Bilge Monitor/Control Systems



BC-4000/8000 Master Display



Input/Output Unit



Single Bilge Control

Feature	BC-8000 Bilge Monitor/Control System	BC-4000 Bilge Monitor/Control System	BSW-1000 Single Bilge Controller
Full visibility into bilge area status and control from one centralized LCD electronic display on the vessel	X	X	Pump Status/Control w/ Auto/Manual Station
Number of bilge areas under control	Up to 8	Up to 4	one
Auto/Manual Pump Control	Up to 8 pumps Up to 88 amp @ 12 volts	Up to 4 pumps Up to 88 amp @ 12 volts	One pump Up to 40 amp @ 12 volts
Inputs for both low and high floats pre-programmed for different control /alarm strategies	X	X	X
Input/Output units provide full monitoring and pump control or monitor only	X	X	
Remote Display Units can be added throughout vessel to provide bilge status and alarms	X	X	
Two-wire network minimizes wiring costs – up to 1000 meters in length	X	X	
Hardwired connection between bilge controller and auto/manual station			X
Input/Output Units operate as fully automatic pump controllers in the event of network failure	X	X	Yes with control in auto
Each I/O unit provides output relay to drive an external horn or light	Up to 3 amp	Up to 3 amp	Up to 200 ma
Pump on delay and pump on alarm time fully programmable	X	X	X
Bilge area names are fully programmable to match vessel configuration	X	X	
3 modes of operation depending on the local regulations – full manual, full automatic and semi-auto for in-port discharge of bilge water	X	X	